

DELAWARE ELEVATOR



LULA
Planning
Guide



Delaware Elevator

Established in 1946, Delaware Elevator is a family-owned full-service elevator company. With over 70 years of experience in the elevator industry, we are committed to providing high-quality, appropriate, and total solutions to our customers' specific needs. Our continued commitment to providing the best quality products, services, and innovative solutions has made us one of the largest independent elevator companies in the nation. Whether new construction or modernization; residential, commercial, or marine, Delaware Elevator continues to satisfy customers by providing the best vertical transportations for the unique challenges of each job.

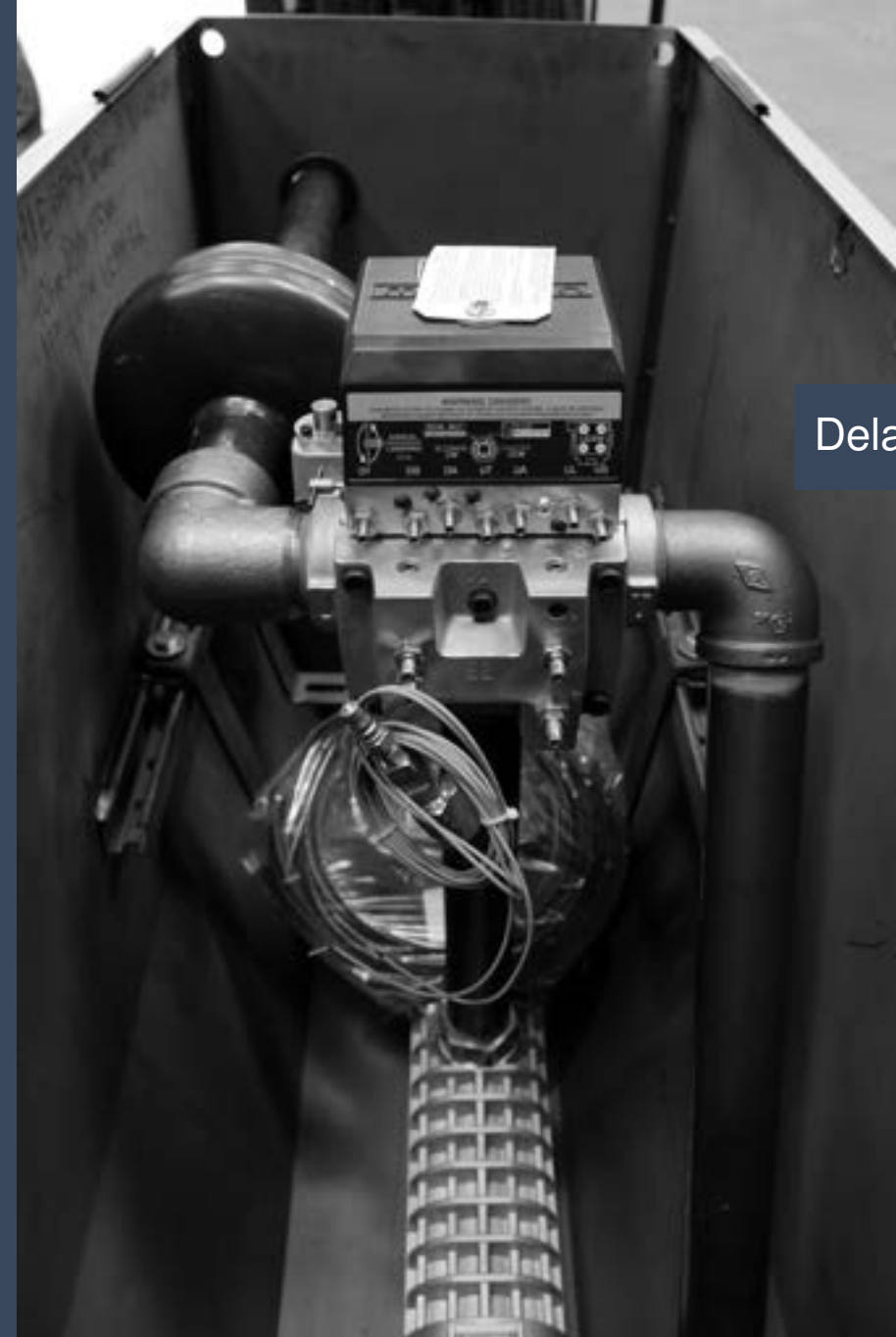

Delaware Elevator Manufacturing

Delaware Elevator Manufacturing (DEM) is a manufacturer and equipment supplier offering complete elevator packages and elevator components tailored to the specific needs of our customers. Positioned in the Mid-Atlantic region, DEM is optimally positioned to service the American Northeast; but, with equipment on four continents, DEM has a proven track record of delivering quality products regardless of geography.



The Olympic LULA

Proudly built in the USA, the Olympic LULA (limited use / limited application) system is the ultimate solution for your commercial low-rise applications. We understand that planning an elevator can be challenging. This guide was created to assist you through the planning stages of your project to ensure that you select the optimal solution. By choosing Delaware Elevator, you can be confident that your elevator will be built to last while meeting all applicable code requirements.



Table Of Contents

- Page 6 Equipment Overview
- Page 7 Features
- Page 8 Cab Designs
- Page 9 Cab Types
- Page 10 Standard Layouts
- Page 14 Pit & Overhead
- Page 15 Machine Room & Electrical
- Page 16 Hoistway Electrical
- Page 17 Rail Wall
- Page 18 Entrance Details
- Page 19 Entrance Details
- Page 20 Sill Details

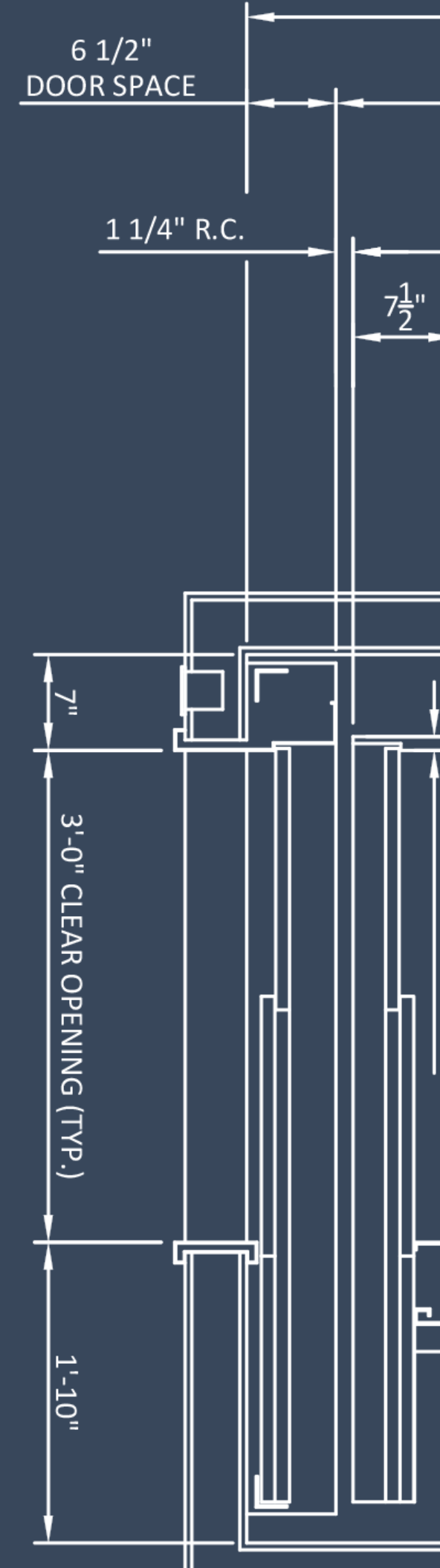

Equipment Overview

The Olympic LULA utilizes a 2:1 roped hydraulic drive system powered by a 5HP submersible power unit. The specifications below are standard dimensions for the initial planning stages (prior to construction).

Capabilities

- Travel: Up to 25 ft.
- Stops: Up to 4 stops
- Capacity: 1400lb
- Speed: 30 FPM

Basic Requirements

- Typical Overhead New Construction: 11' - 2"
- Minimum Overhead Existing Building: 9' - 6"
- Minimum Pit Depth With Pit Prop Device: 14"
- Minimum Pit Depth Without Pit Prop Device: 42"
- Machine Room Within 50 ft

Roped Hydraulic Drive

- 2:1 Roped Hydraulic
- Motor: 5 HP submersible
- Valve: Blain EV100
- Power Supply Single Phase: 240VAC
- Power Supply Three Phase: 208VAC
- Power Supply Three Phase 460VAC (Available with Step Down Transformer)

Safety & Code Features

- Overspeed Valve
- Automatic Cab Lighting
- Emergency Cab Lighting
- Infrared Door Protection System
- Emergency Battery Lowering
- Oil Temperature Protection
- Phone Line Loss Protection (If Applicable)
- Keyed Emergency Stop Switch And Alarm Button
- Braille Tags
- Fire Service Phase 1

Optional Features

We understand that not all projects are standard. The Olympic LULA system is offered in custom dimensions to ensure that your vision is achieved. Whether you have a non-standard hoistway or want to enhance your cab interior with custom finishes; our LULA system can be modified to your needs.

- Custom Car Sizes
- Additional Travel and Floor Stops
- Custom Width Entrance Frames
- Direct Hydraulic Drive in Lieu of 2:1 Roped Hydraulic
- Wide Variety of Laminate Options
- #4 Brushed Stainless Steel Cab and Canopy
- #4 Brushed Stainless Steel Cab Inlay
- Position Indicators in Hallway Call Stations
- Protection Pads and Hooks
- Non-Slip Rubber Mat Flooring
- Exhaust fan in Ceiling
- #4 Brushed Bronze Cab Metal Finishes
- #4 Brushed Bronze Faceplate/Button Finishes
- Car Travel Lantern with Audible Signal
- Drop Ceiling with LED Downlights
- LED Downlights Recessed in Canopy
- #4 Brushed Stainless Steel Hallway Entrances
- Keyed Hoistway Access at Upper and Lower Landing

Standard Features

Our standard package includes everything you need to install your LULA package. Although we offer custom sizes and optional features, the following items are included in the standard Olympic LULA package.

Cab & Entrances

- Flush Laminated Shell Walls
- Painted Steel Canopy With Lexan Diffused Panels
- #4 Brushed Stainless Steel Handrail
- #4 Brushed Stainless Steel Entrance Frame
- #4 Brushed Stainless Steel 2 Speed Doors
- #4 Brushed Stainless Steel Car Operating Panel
- Aluminum Sill(s)
- Car Top inspection Station

Fixtures

- #4 Brushed Stainless Steel Hall Stations
- Digital Position Indicator with Directional Arrows in Car
- ADA Hands Free In-Car Telephone



Cab Designs

Laminated Panels
(Flush or Removable Panels)
Shown in Woodgrain Laminate



Laminated Panels
(Flush or Removable Panels)
Shown in White Laminate



#4 Stainless Steel
(Painted Shell Available as well)



Cab Types

The Olympic LULA system is offered in a multitude of sizes and opening options to suit the vertical transportation needs of your project.

Front Opening

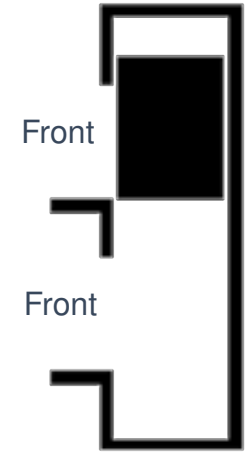
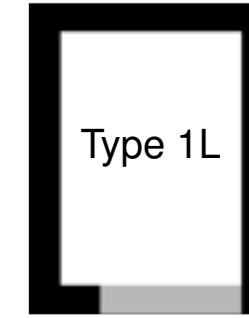
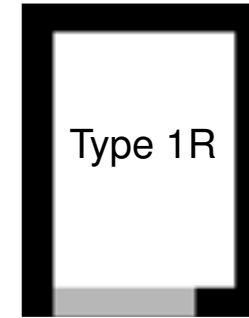

Front & Rear Opening

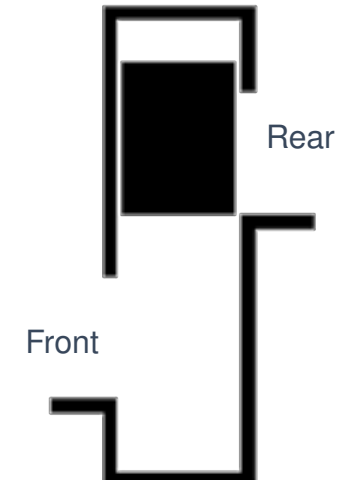
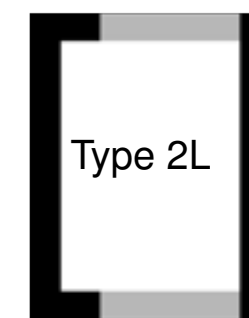
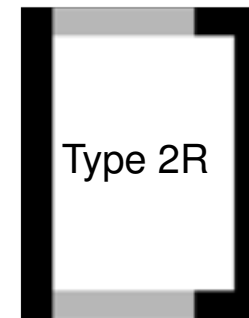

Front & Side Opening

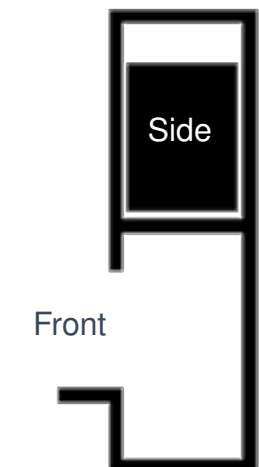
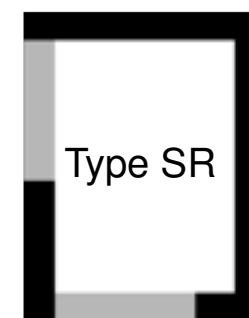

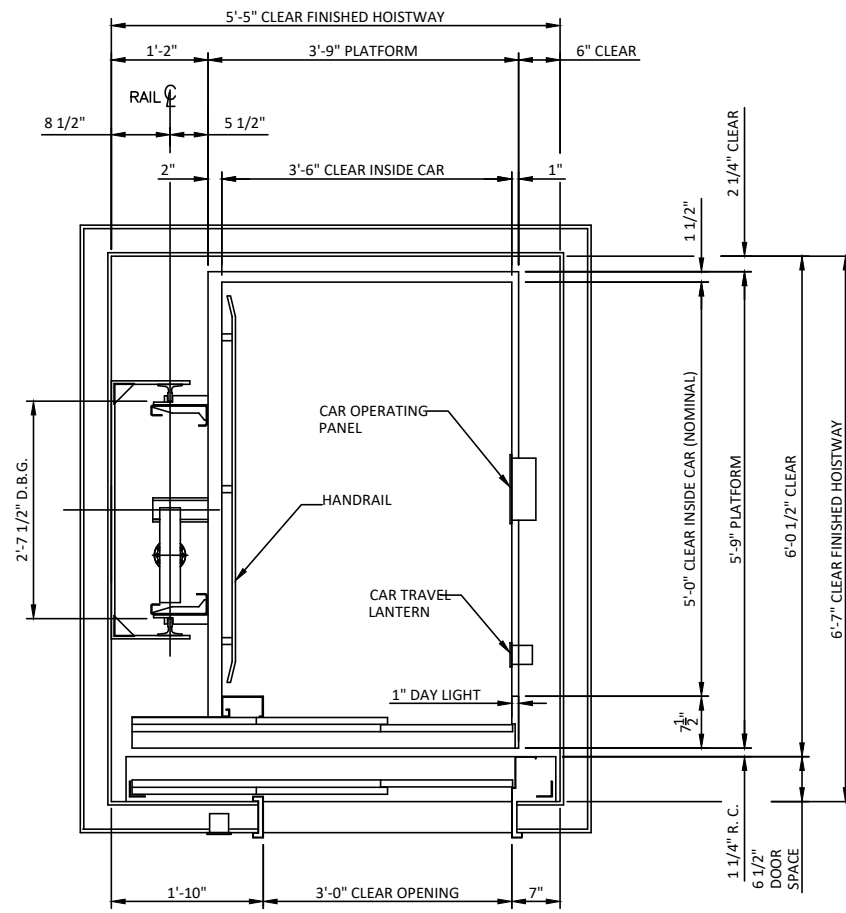

42" X 60" 1L

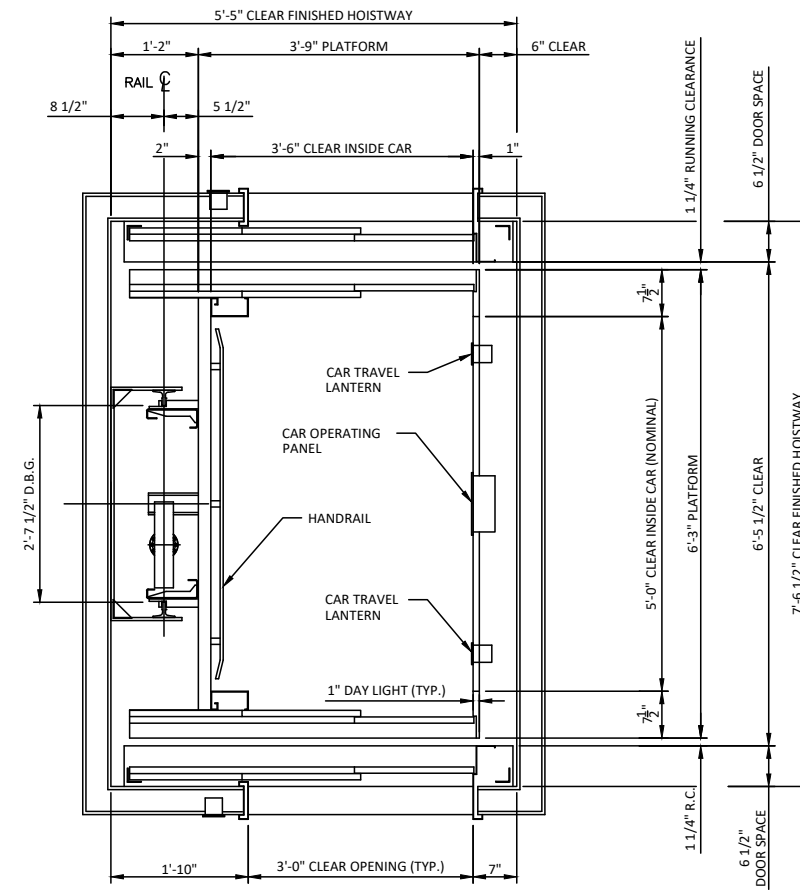

42" X 60" 2L

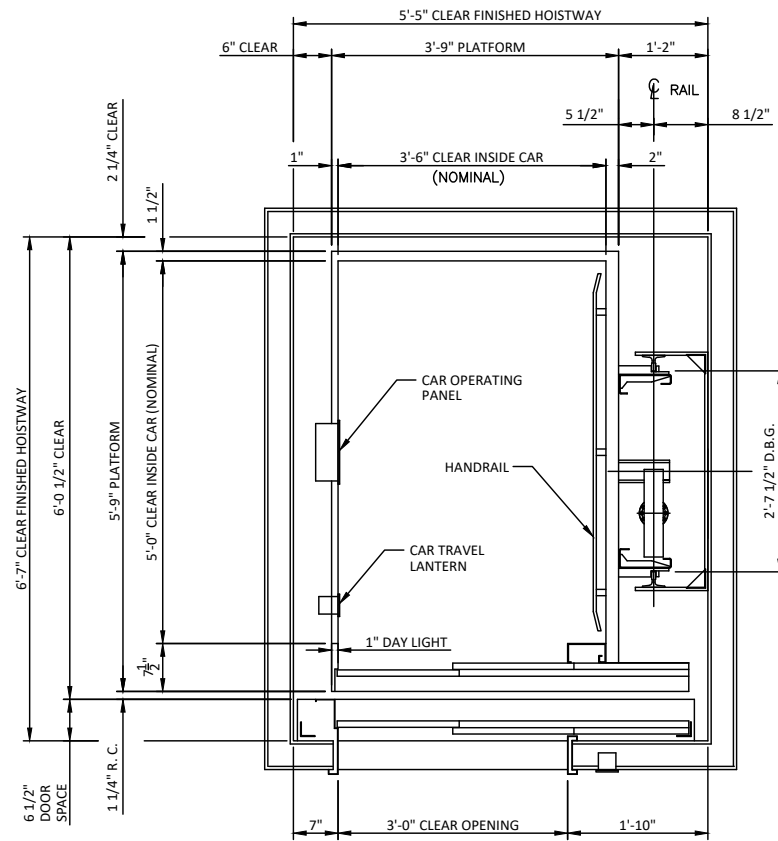

42" X 60" 1R

42" X 60" 2R

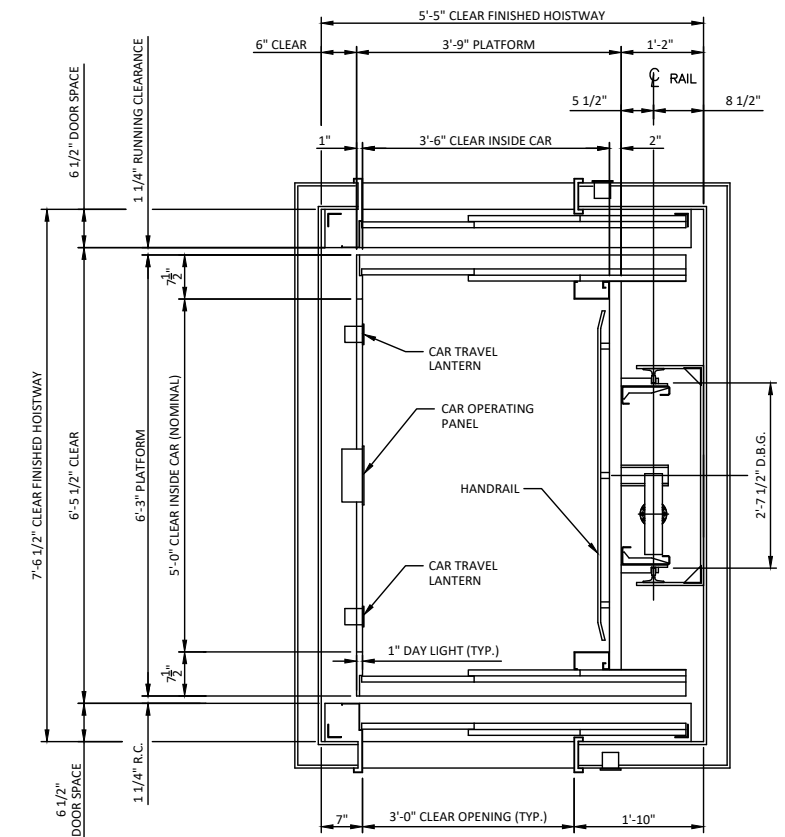

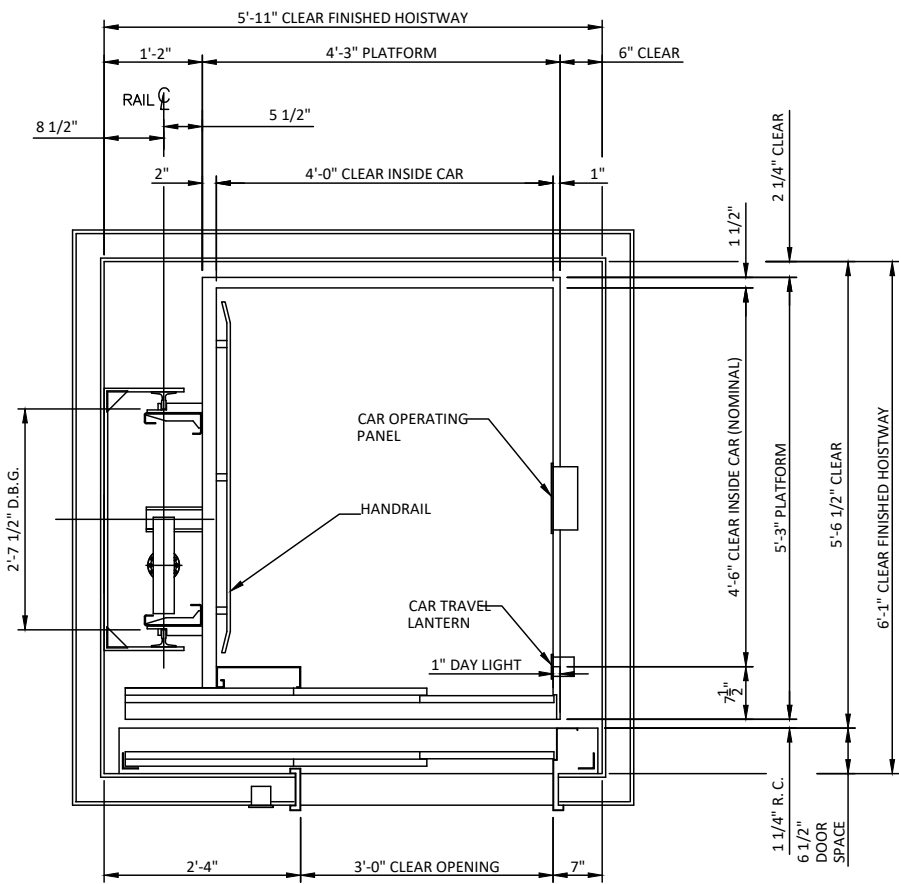

48" X 54" 1L

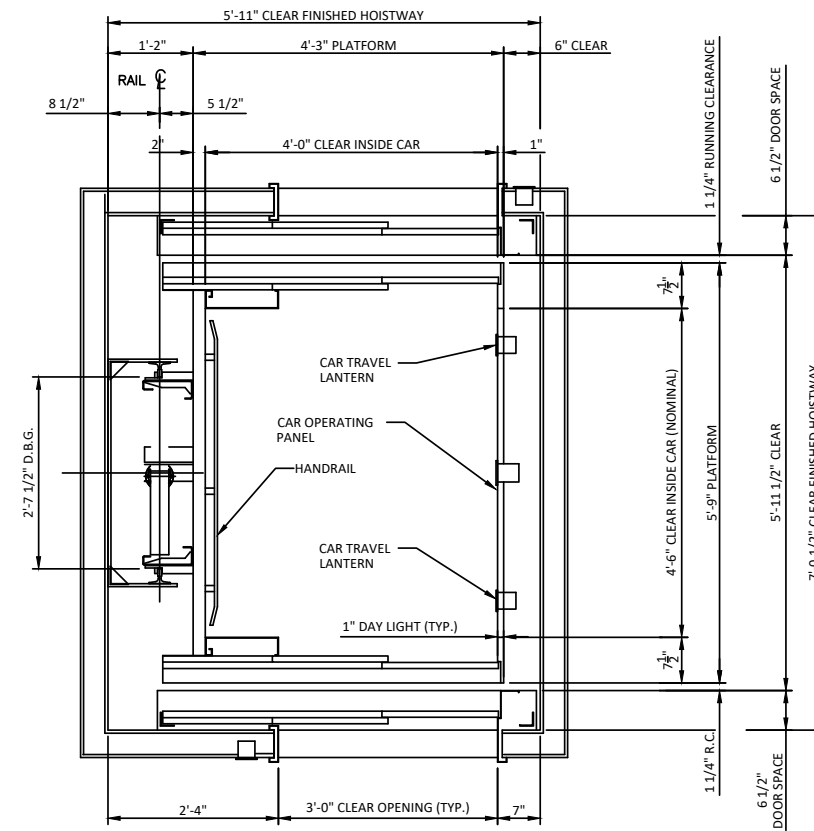

48" X 54" 2L

48" X 54" 1R

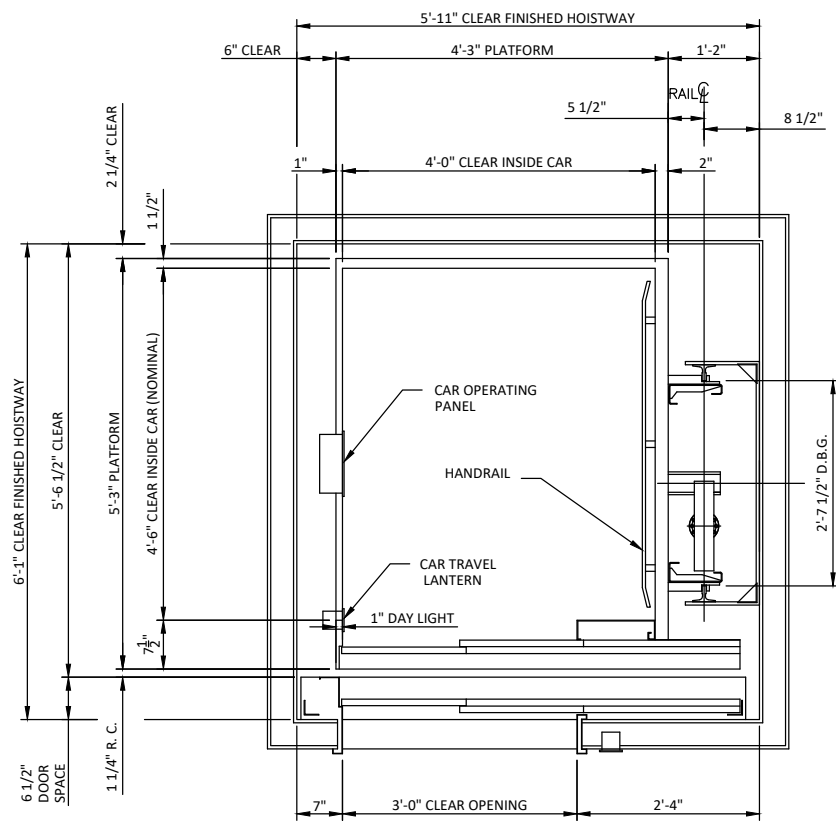

51" X 60" SR

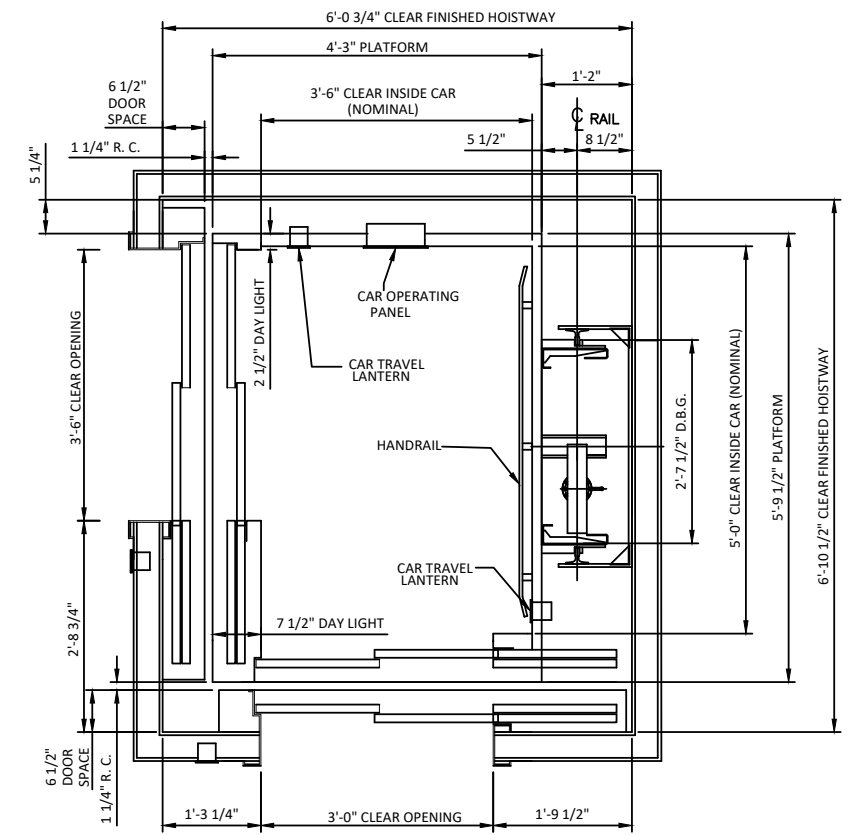

Machine Room & Electrical

Pit & Overhead

Overhead

The Overhead is the distance from the floor of the top landing to the top of the hoistway.

Requirements

New Construction: 11' - 2"
 Existing Building: 9' - 6"
 Lower Overhead achievable with a cartop prop.

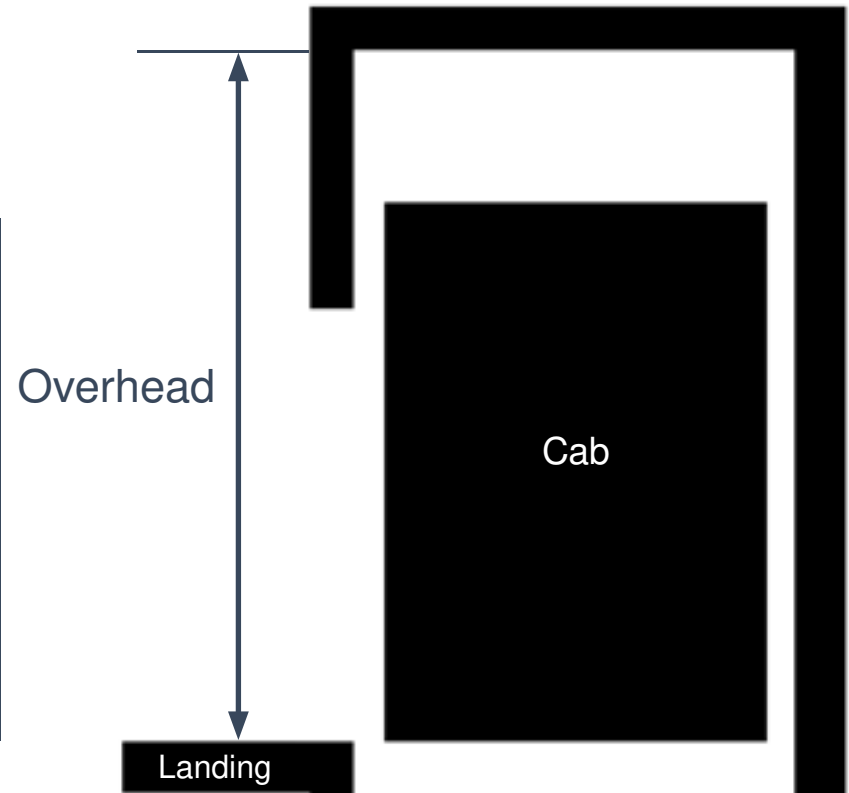

Pit Depth

The Pit Depth is the space below the elevator cab from the lowest landing to the bottom of the hoistway.

Requirements

With Pit Prop Device: 14"
 Without Pit Prop Device: 42"

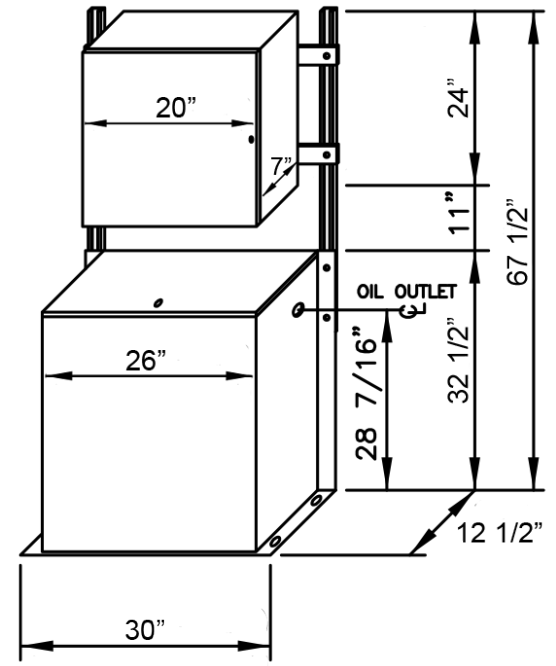
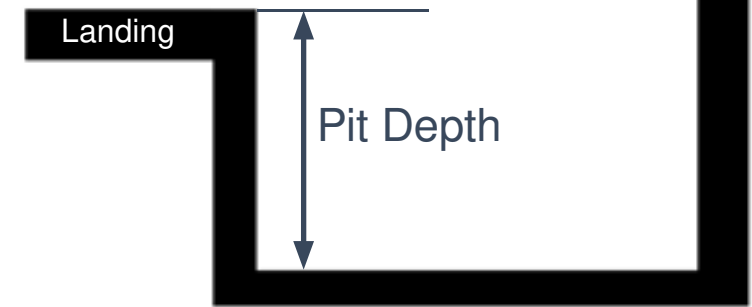

Controller Tank Specifications

Minimum Required Clearance in Front	39"
Valve and Manual Lowering Handle location	Inside Tank
Rupture Valve	Included
Tank to Controller Wiring	Quick Connect
Controller Layout	PCB
Keyed Lock to Tank	Yes
Tank Capacity	15 Gal
Max Dry Weight	147 lbs
Max Filled Weight	312 lbs
Operating Environment	50°F - 80°F

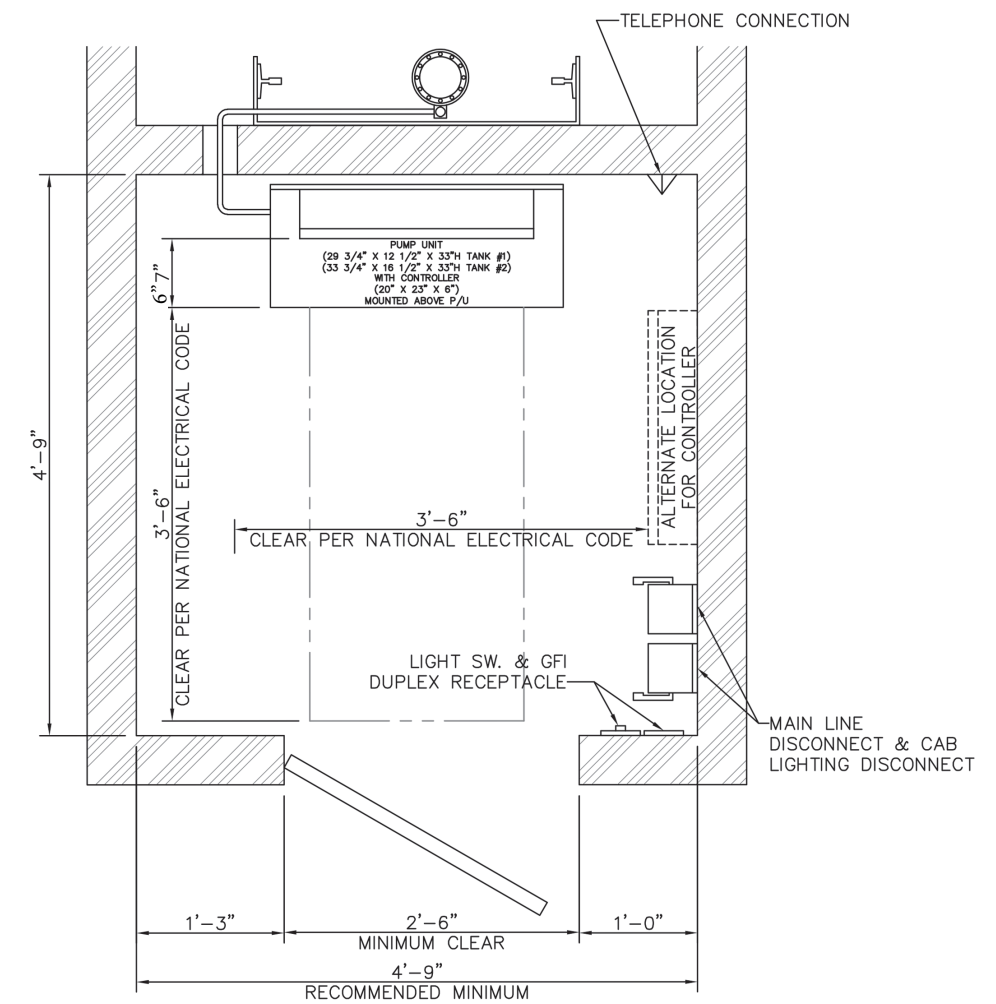

*The information in this document is not an exhaustive list. Local code should be reviewed.

Machine Room & Hoistway Electrical Notes

The machine room must be built in accordance to applicable building codes and regulation. This includes adequate ventilation to maintain a temperature between 50°- 80°F (3600BTU per Hour).

Two 3" sleeves are required to connect machine room to elevator hoistway.

The machine room door must be self-closing and self-locking.

A light switch must be located within 18" of the machine room door.

The machine room is required to be free of all pipes and obstructions that are not required for the elevator's operation.

The machine room lighting must be a minimum of 19 foot candles at working surface. The lighting must be protected to prevent damage or contact with a hot bulb.

Per NEC code, a 30" X 36" clear working space is required in front of the disconnect switches.

The pump and controller require a 39" clear working space.

The mainline disconnect must have an auxiliary normally open contact.

A power outlet should be located within 18" of the machine room door.

A lockable fused disconnect switch in the off position must be located within 18" of the machine room door (Fuse must be 35A 208V 3 phase or 60A 230/240V single phase)

A telephone circuit must be connected to a dedicated, non-switched, outside line or a 24 hour central exchange.

**The information above does not include all requirements. Local code should be reviewed.*

Hoistway Electrical

Sumps, sprinkler systems, smoke and heat detectors may be required at the top or bottom of the hoistway if required by local code.

A protected light with a light switch accessible without entering the pit is required.

A GFCI service outlet must be installed in the pit.

Due to limited running clearances it is recommended that the electrical contractor provides feeds for these items, but not trim out these items until the elevator installation is complete.

Rail Wall Information

Wood Framing

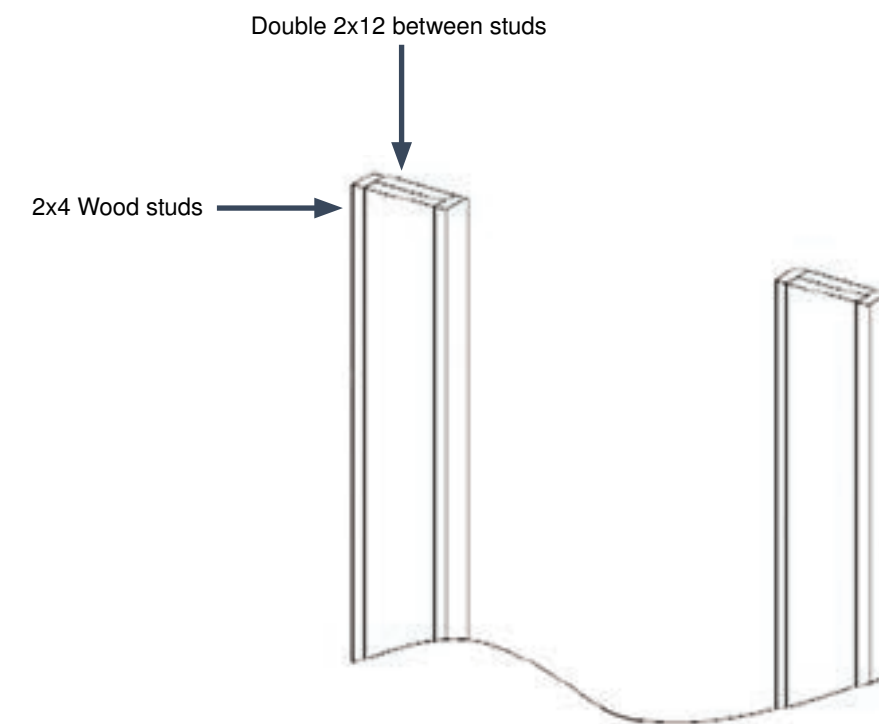
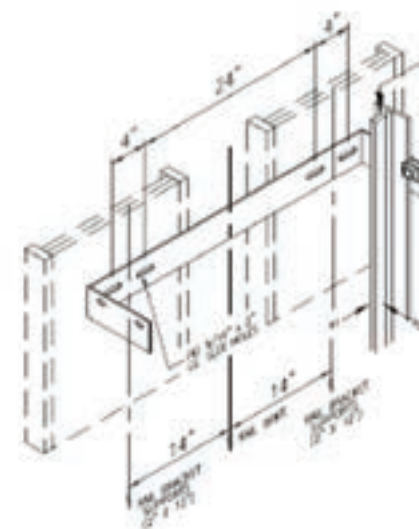

Concrete

CMU cells should be filled. Preferred mounting utilizes wedge/sleeve anchors. Through-bolting is available when back side of load wall is accessible prior to finish.

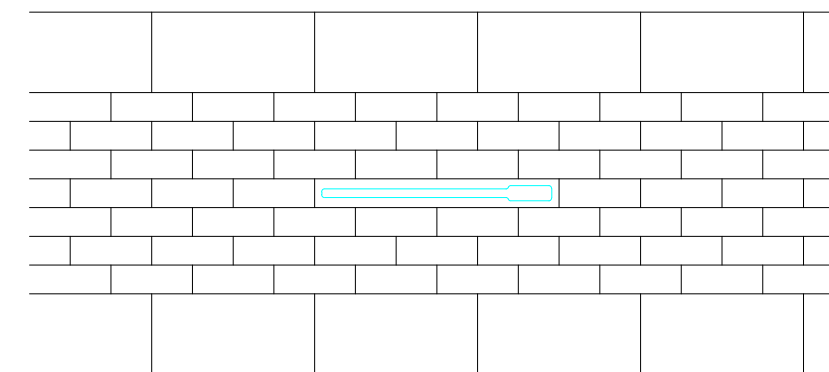
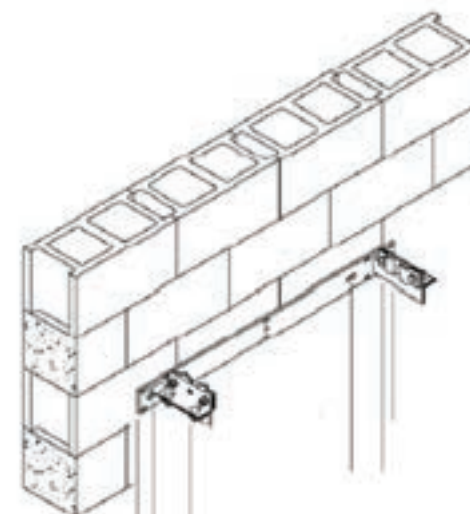

RAIL BRACKET INSERT INSTALLATION DETAILS

INSERT OCCURRING IN BLOCK WALL TO BE SET IN COURSES OF BRICK BY GEN. CONTR.

Entrance Details

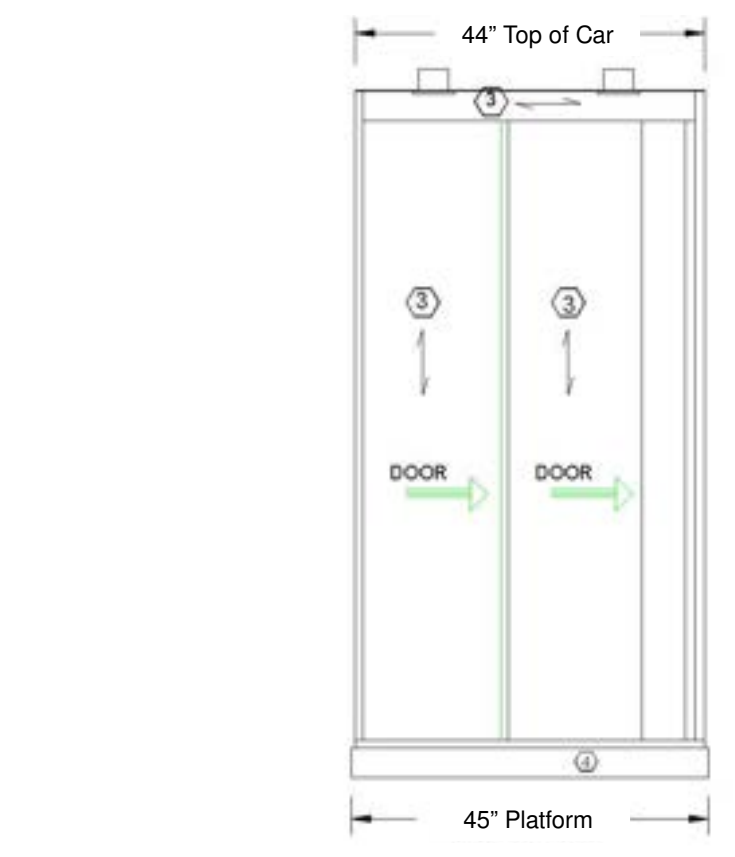
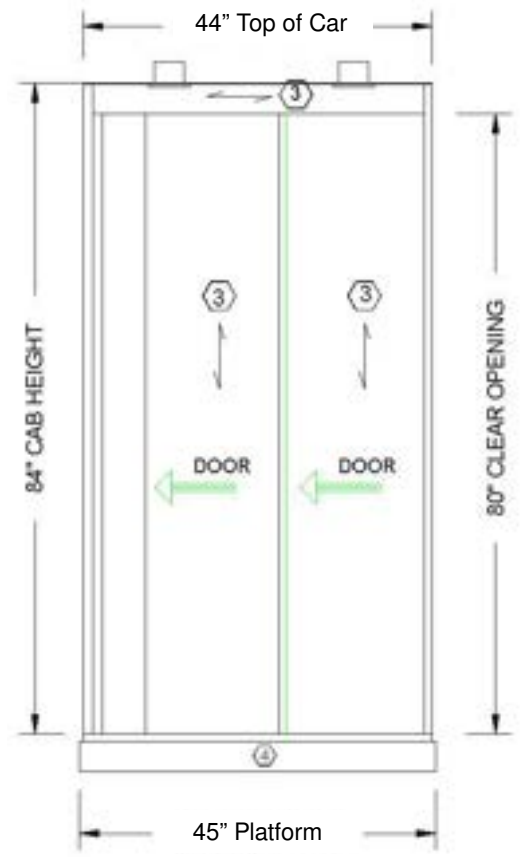
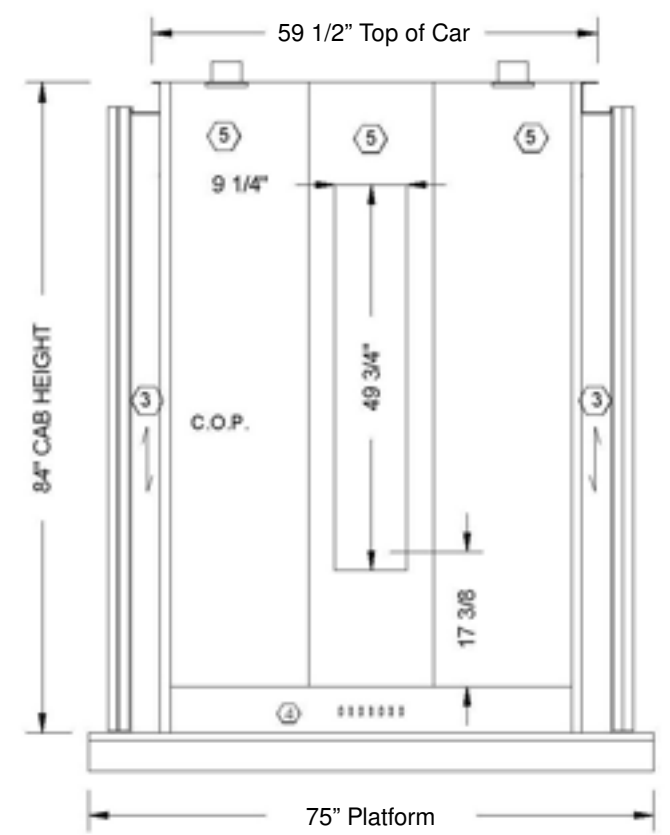
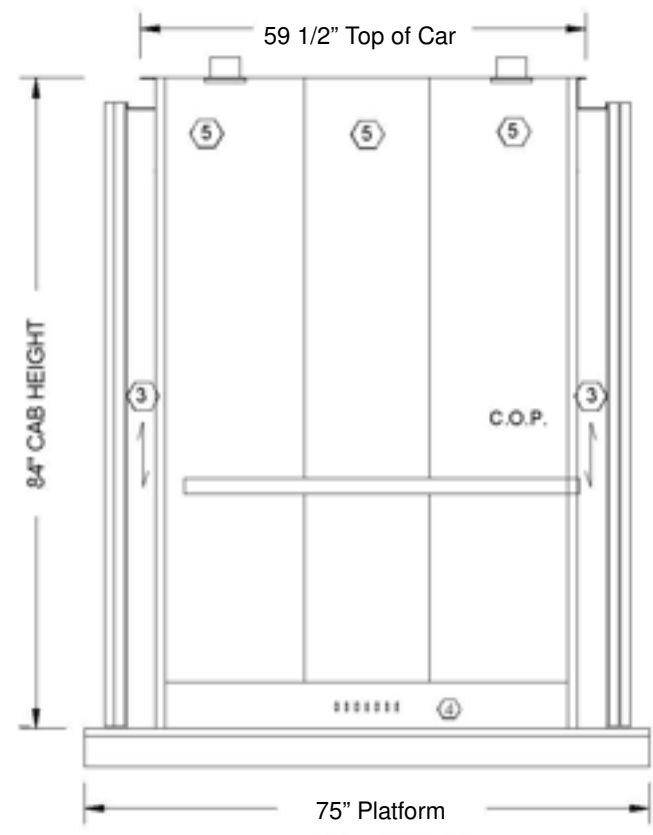
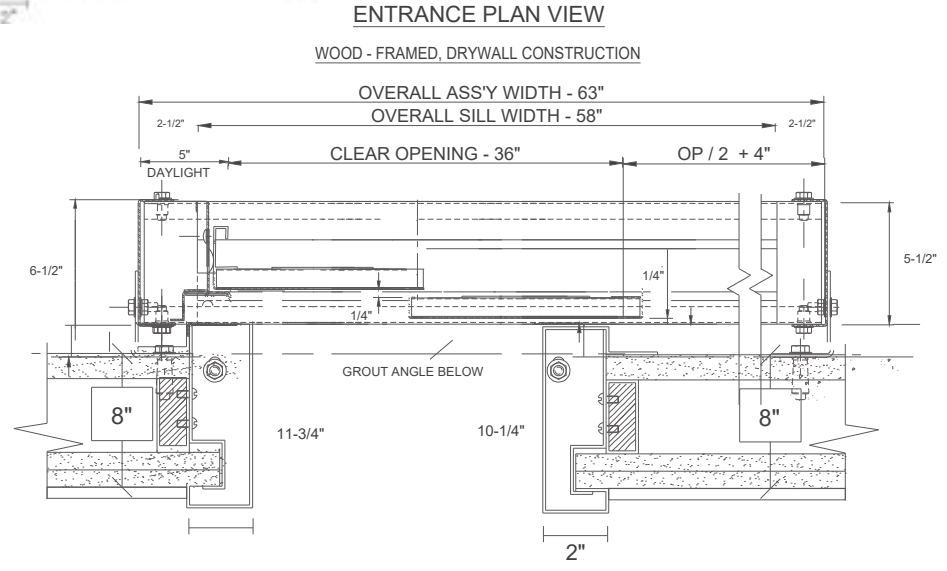
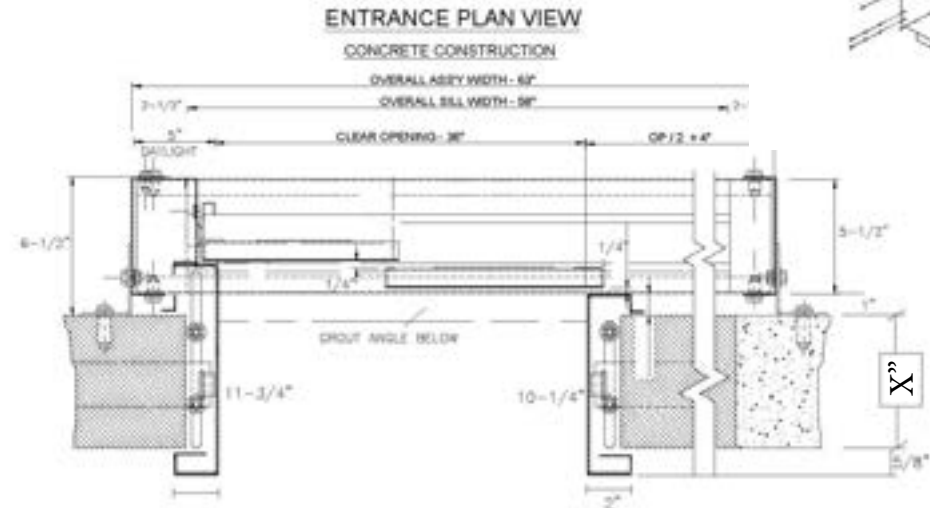
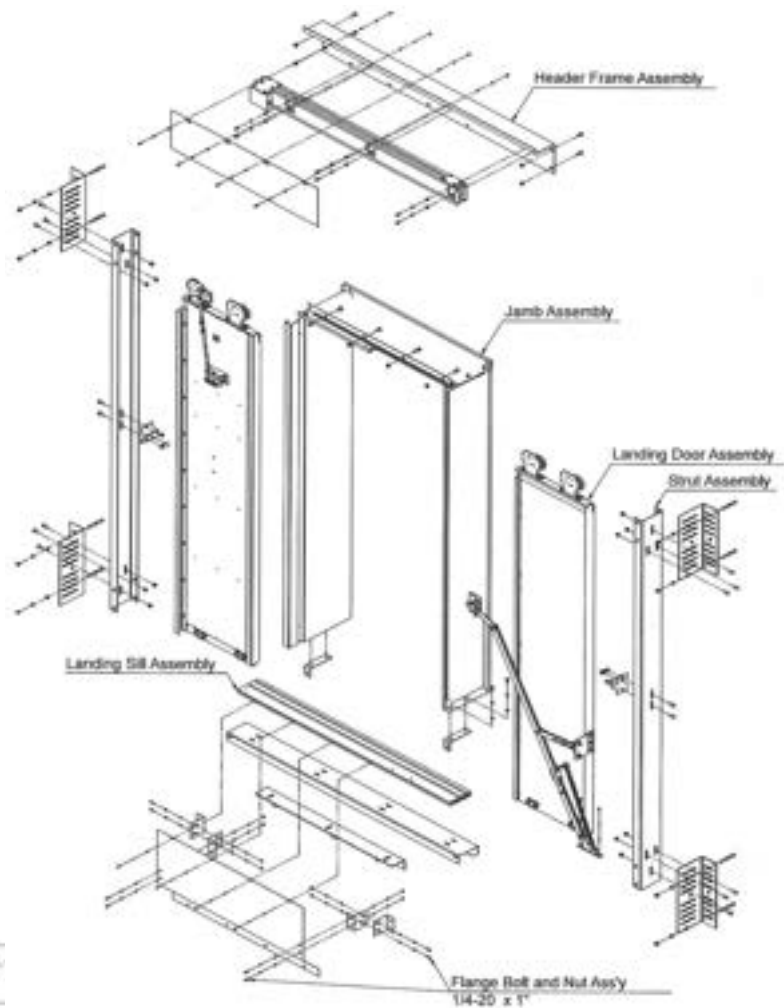

Sill Details

Notes

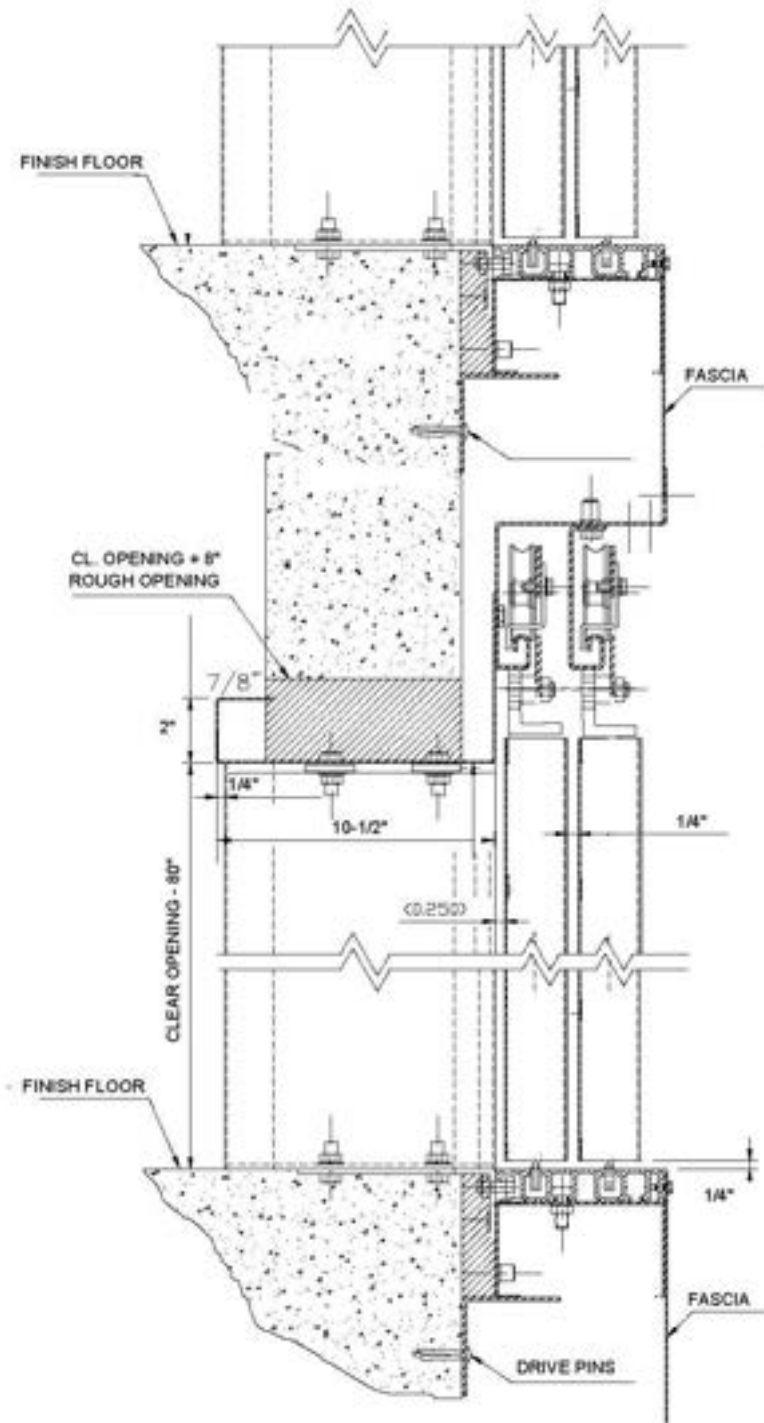
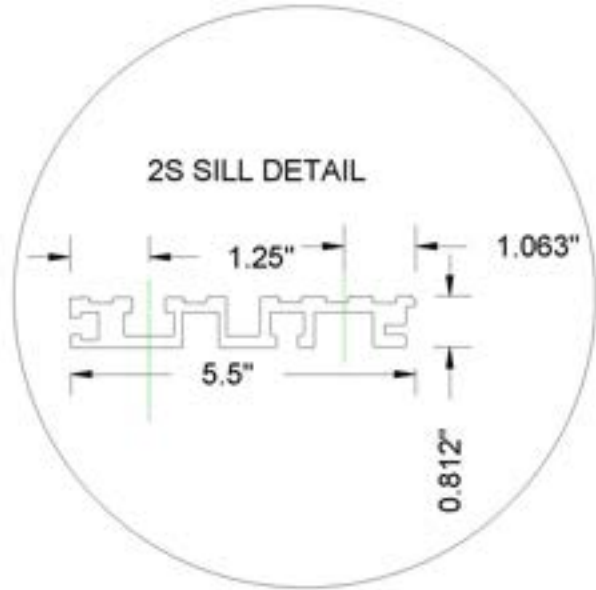

VERTICAL SECT THROUGH HEAD AND SILL



DELAWARE ELEVATOR MANUFACTURING

27685 ROCKAWALKIN RIDGE RD.
SALISBURY, MD 21801

410-749-3489

MANUFACTURINGSALES@DELAWAREELEVATOR.COM

WWW.DELAWAREELEVATOR.COM

